

IHAGEE
“Vielzweck”

Ihagee "Vielzweck"

The Ihagee "Vielzweck" is based on the "Add On" principle, whereby the user of EXAKTA equipment can, according to requirements and budget, gradually increase the versatility of this equipment, utilising the many interchangeable accessories available in the EXAKTA range.

The "Vielzweck" can also be used with EXA models Ia und IIb; there are, however, a few limitations with the EXA Ia.

The EXAKTA range of cameras, provided with a few basic accessories, have proved very successful in many fields of application. The

addition of the "Vielzweck", however, meets the most exacting requirements of the advanced amateur, professional photographer and scientific worker.

The object of this booklet is to summarise the main applications of the "Vielzweck". In addition, the equipment can also be conveniently arranged to accomplish many other photographic tasks.

IHAGEE KAMERAWERK AG
8016 DRESDEN

The principal applications of the Ihagee "Vielzweck"	Page
Transparencies	13
Medical photography	35
Photomicrography	27
Macrophotography.....	3, 8, 18
Copying	21
The tripod in connection with long-focus and heavy lenses	33
Stereo-Photography	6
Producing duplicate negatives.....	13

Component Parts	Page
The Swing Angle Attachment	3
The Bellows Attachment	8
The Transparency Copying Equipment ...	13
The Miniature Bellows Attachment	18
The Copying Stand and Repro Unit	21
The Tripod Plate and Swing Angle Top ..	33
The RB 1 Ring-Flash Unit.....	35

Hints

Some hints concerning Macrophotography and Photomicrography	39
The "Vielzweck" and EXA Models	42

There may be slight deviations between the actual models and illustrations in this booklet.

The basic equipment of the Ihagee "Vielzweck" consists of copying stand, bellows attachment and transparency copying equipment, all other items presented in this booklet must be ordered separately.

The Swing Angle Attachment

(Figs. 1 . . . 3)

It consists of the swing angle top (10) and the focusing slide (1). The swing angle top (10) is pushed onto the slide rail (2) of the focusing slide: For this purpose loosen the locking lever (11) by swinging it to the left up to the stop. Push the swing angle top on to the end of the slide rail (2) (recognizable by the large scale). Set the locking screw (3) with the cut-off part of its head on a level with the slide rail (2). With the swing angle top pushed on to the slide rail, slightly tighten the locking screw (3), causing the round part of the screw head to project a little above the slide rail, which will prevent the swing angle top from slipping off.

With the swing angle top in use, the scales on the slide rail (2) become invalid. You are

Fig. 1

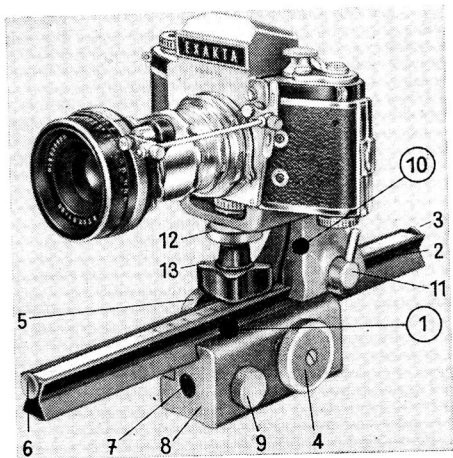

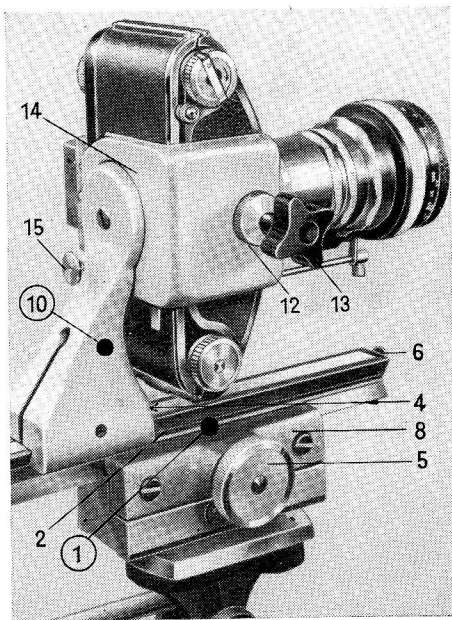

able to set the swing angle top and lock it in any desired position by simply turning down the locking lever (11) to the right. As shown in Figs. 1 and 2 the camera is fastened to the angular piece (14) by means of the fastening screw (13). This fastening screw is designed for cameras featuring an English tripod socket ($1/4''$) or a Continental tripod socket ($3/8''$). Remember that the locking-nut (12) has to be screwed in between the angular piece (14) and the head of the fastening screw (13). As soon as the fastening screw has been driven deep enough into the tripod socket of the camera, the locking-nut must be screwed against the angular piece. To move the camera from the horizontal to the vertical position, or vice versa, the angular piece (14) is movable in both directions on pulling out the locking knob (15). This knob clicks in automatically when the angular piece (14) has completed a 90° rotation. For horizontal working the swing angle attachment, on to which the camera has

Fig. 2

been screwed, is simply set upon a table. The swing angle attachment will be very useful when connected to a tripod either in horizontal position, or with the aid of a tilting head for a tripod, it can be fastened in a vertical position. An English or Continental tripod socket will be found at the bottom of the sliding block (8). The extension required for the picture ratio is produced by inserting bayonet rings and tubes. For critical focusing the swing angle attachment offers two possibilities: Either you move the swing angle top (10) with the camera attached on the slide rail (2) to and fro (do not forget to loosen locking lever (11) and retighten it), or you make use of the rack of the focusing slide and shift the slide rail with swing angle top and camera mounted. Shifting the tripod will be hardly necessary, for the swing angle attachment's wide focusing allows ample play for varying the subject distance. Sharp focusing is controlled on the reflex image of the camera. Moving the slide rail (2) to and fro is accomplished by actuating the two rack-and-pinion knobs (4 and 5). When working with the appa-

ratus in vertical position the rack-and pinion knob (5) serves for locking the slide rail (2), preventing its being pulled down by the weight of the camera. The rack-and-pinion knob (5) is screwed clockwise tight against the sliding block (8) during which performance the opposite knob (4) must be held tight. If the rack-and-pinion knob (5) is to act once more as a focusing knob, it must be turned away from the sliding block (8) and fixed in its endposition during which performance the knob (4) must again be held tight. Locking screw (6) prevents the swing angle top from slipping off the slide rail (2) while working with the apparatus in vertical position. (Hole (7) and locking knob (9) serve to receive the transparency copying equipment; please see also page 13).

It is recommended to use the autocouple extension release (Figs. 1 and 2) when using bayonet rings and tubes in connection with the fully automatic spring or pressure diaphragm mechanism of the lenses.

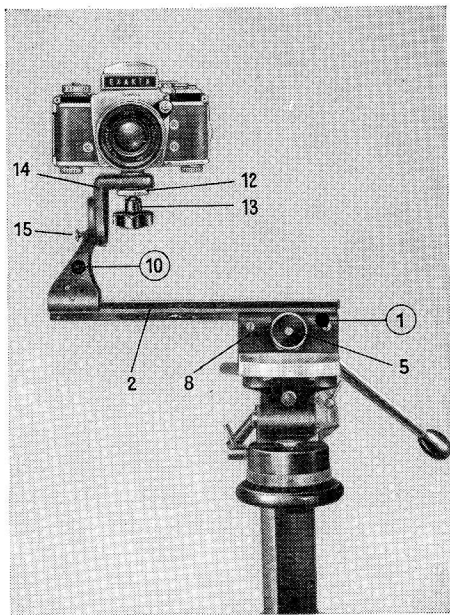

Stereo Photography with Swing Angle Attachment

In stereo (3 dimensional) photography you are not absolutely bound to make both exposures simultaneously using two lenses or (as in the case of the Stereo Attachments of our cameras) two prisms. The two stereoscopic pictures can be taken in succession. The camera, in this case, has two different standpoints and the distance between these two points is called the "stereoscopic base"; the object must, of course, be motionless. The stereoscopic effect is considerably enhanced by "wide base" exposures, in which the distance between the two pictures is not the usual 6.5 cm - interocular distance -, but where a greater lateral movement of the camera is possible. The swing angle attachment connected to a sturdy tripod, permits making stereo exposures with a base of almost 50 cm. The focusing slide (1) is fixed to the tripod at a right angle to the viewing line

Fig. 3

(Fig. 3). While pulling knob (15), turn the angular piece (14) upwards, bringing the plate with the hole for the fastening screw to the top, ready to accept the camera at a right angle to the focusing slide for horizontal exposures. The camera is fastened by means of fastening screw (13) and the locking nut (12) is again screwed in between the head of the fastening screw and the angular piece (14). The stereo base is obtained either by the swing angle top (10) on the slide rail (2) or by additional

adjustment of the slide rail (2) itself, by means of the rack-and-pinion mechanism of the focusing slide.

Nos. for ordering

Focusing slide (1)	155.01 U 7
Swing angle top (10)	155.03
Swing angle attachment (1 + 10)	155.08

Please state whether the camera has an English or Continental tripod socket.

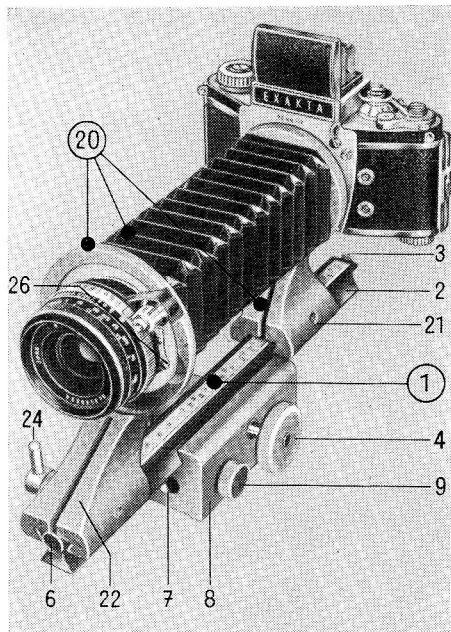

Bellows Attachment

(Figs. 4 and 5)

It consists of the bellows top attachment (20) and the focusing slide (1). The locking levers (24 and 25) located on camera holder and lens holder respectively must be loosened by turning them counterclockwise up to the stop. Camera holder and lens holder have to be pushed together so that the bellows are protected.

First the lens holder (22) and then the camera holder of the bellows top attachment (20) are pushed on to the tail-end of the slide (recognizable by the largest values on the scale).

Fig. 4

ready for vertical exposures. If you intend working in horizontal position, turn the camera back again by 90° up to the stop. You are at liberty to use any standard or special supplementary lens to fit our single lens reflex cameras, with the exception of extreme wide-angle lenses with a focal length of less than 30 mm. Also lenses featuring very long focal distances are not very practicable on the bellows attachment. When fixing the lens into the lens holder (22) the red dots on the bayonet fittings must meet. Insert the lens into the bayonet mount and turn clockwise until locking lever (26) clicks in.

The smallest increase in extension obtainable with the aid of the bellows attachment is 35 mm, the greatest approximately 220 mm. The 35 mm extension increase, when using 50 mm standard lenses, shows an image scale of reproduction of 0.7 and subjects measuring 34 mm x 51 mm are reproduced in full. The wellknown special lens Jena T f 2.8/50 mm is available with sunk mount, for taking larger

The locking screw (3) must be set in such a way that the cut-off section of the screw lies on a level with the upper surface of the slide rail (2). Having pushed the holders on, tighten locking screw (3) causing the round part of the screw head to project the surface of the slide rail, thus preventing an accidental slipping off of the bellows top attachment. It is advisable to place the bellows top attachment (20) towards the opposite end of the slide rail (2) and to lock the lensholder in this position by turning lever (24) to the right. It will be possible to move the camera holder (22) to and fro on the slide rail (2), as required for focusing. The camera holder can be locked in position by turning lever (25) to the right. Of course, the lens holder (22) can also be moved.

When fastening the camera to the camera holder (21) make sure that the red dots on the two bayonet rings are exactly opposite each other. Then turn the camera clockwise (in viewing direction) until the locking lever clicks into the bayonet fitting. The camera is now

subjects with the aid of the bellows attachment. It will also allow focusing at longer distances (up to infinity). The black figures on the scale of the focusing slide (1) signify the increase in extension in mm for the usual standard, short- or long-focus lenses of our cameras, whereas the red figures refer to the increase in extension when using the special lens Jena T f 2.8/50 mm with sunk mount. This lens can, therefore, cope with extension increases ranging from 0 up to 185 mm. The scale values hold good only with lens holder (22) in position against the front stop of the slide rail (2). It is the measurement visible against the upright rear surface of the camera holder that counts.

If the bellows top attachment (20) is to be removed from the focusing slide (1), it is in all cases advisable, for the sake of preserving the bellows after loosening the levers (24 and 25), to push lens holder (22) and camera holder (21) together, and then to draw them together from the slide rail (2). It will be necessary to set the locking screw (3) so that its lateral cut-

off section lies on a level with the upper surface of the slide rail (2).

For horizontal working, the bellows attachment fastened to the camera can be set on a table. The bellows attachment can be fixed on a sturdy tripod either in horizontal position or, with the aid of a pan and tilt tripod head, in a vertical position. An English and a Continental tripod socket will be found at the bottom of the sliding block (8). Moreover, the bellows attachment is one of the essential component parts of the repro unit (see page 21).

The necessary increase in extension is obtained by drawing out the bellows: Loosen lever (25) located on the camera holder (21) and slide the camera holder up to the desired scale value. Critical focusing is accomplished by actuating the cog-wheel mechanism of the focusing slide and by moving to and fro the slide rail (2) with the bellows top attachment and camera mounted. Shifting the tripod will hardly be necessary, for the bellows attach-

ment's wide focusing range allows ample play for varying the lens to subject distance. However, in case the lens to subject distance is unchangeable, critical focusing can be accomplished by moving the camera holder (21) to and fro on the slide rail (2). Of course, sharp focusing is controlled on the reflex image of the camera. Moving the slide rail (2) to and fro is accomplished by actuating the rack-and-pinion knobs (4 and 5). When working in vertical position the rack-and-pinion knob (5) can serve for fixing the slide rail (2), thus preventing it from being pulled down by the weight of the camera. In this case the rack-and-pinion knob (5) is screwed clockwise tight against the sliding block (8), whilst the opposed knob (4) is held tight. If the rack-and-pinion knob (5) is wanted again for focusing, turn it away from the sliding block (8) and tighten it in its end position. Rack-and-pinion knob (4)

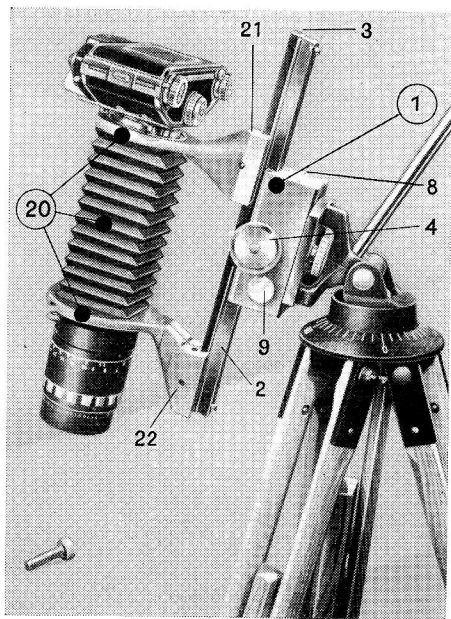

Fig. 5

must be held tight. Locking screw (6) prevents the bellows top attachment from slipping off the slide rail (2), while working with the apparatus in vertical position. (The hole (7) and the locking knob (9) serve to receive the transparency copying equipment, please see also page 13.)

Nos. for ordering

Focusing slide (1)	155.01 U 7
Bellows top attachment (20)	155.02
Bellows attachment (1 + 20)	155.10
Special lens Jena T f 2.8/50 mm with sunk mount	128

The Transparency Copying Equipment

(Figs. 6 and 7)

The desire to make transparencies from 35 mm black-and-white and colour negatives, and 35 mm duplicate negatives from reversible transparencies, led to the designing of the transparency copying equipment. Copying is an optical performance based on close-up photography, necessitating the use of the bellows attachment. For exposures at a ratio of 1:1 the extension increase must be equal to the focal length of the lens in use. The scale of the bellows attachment has to be set to an extension increase equal to the focal length of the lens.

Fig. 6

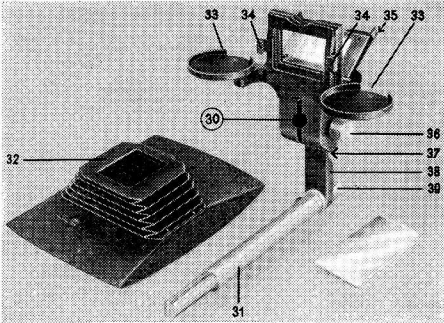

The transparency copying equipment (30) has to be fixed to the focusing slide (1) by means of the coupling rod (31). Tighten the little knob (9), (see Fig. 4), and the transparency copying equipment is fastened securely to the focusing slide. The transparency copying equipment (with bellows attachment) is generally chosen for 35 mm objects in the horizontal position in connection with the repro unit (see Fig. 7). You will find it most convenient to do this kind of work sitting down and looking straight into the Penta Prism or into the built-in Prism Viewfinder of the camera. (Of course, the Finder Hood, too, can be used for focusing with the EXAKTA Varex).

Before use, the transparency copying equipment (30) has to be adjusted so that the aperture of the picture gate (35) will always fit precisely into the film window of the camera in the horizontal position. After the transparency copying equipment (30) has been fixed to the focusing slide (1), you place any negative strip into the folding picture gate (35), making sure that

one of the negatives lies exactly in the aperture of the picture gate. You illuminate your object either with normal bulbs (preferably not less than 60 watts), or with photolamps. Depending on the amount of heat radiating from the light source, the lamp is placed about 30 cm to 50 cm behind the picture gate (35), the opal glass of which yields an even distribution of light. Open the back of the camera, which has been fixed as shown in Fig. 7, place the little ground glass on the film window of the camera and with your camera prepared - as described before - for a reproduction ratio of 1:1, you focus, by means of the rack and pinion knobs (4 and 5), on the image visible in the ground glass. Set the shutter to T and open it. Loosen the nut (39) with the aid of a screw driver. The holder (38) can now either be turned around the axis of the coupling rod (31) or moved slightly in a horizontal direction until the image in the ground glass comes to lie exactly between the short margins of the film window in the camera. The nut (39) can now be screwed tight, as it will not

be loosened again. Focusing in vertical position is performed by rise or fall movement of the picture gate (35) on the holder (38), for which purpose the lever (36) has to be loosened. Having been thus adjusted, the image in the ground glass must lie precisely between the long edges of the film window in the camera. After final adjustment, the lever (36) must be tightened again. To mark the correct adjustment we advise making a pencil stroke on the holder (38) at the point designated by the arrow (37) in Figs. 6 and 7. This adjustment always has to be observed when making duplicate negatives and transparencies on a reproduction scale of 1 : 1. The object needs only to be placed accurately into the picture gate (35) and upon focusing either in the Finder Hood, in the Penta Prism or in the Prism Viewfinder of the camera with the aid of the rack-and-pinion knobs (4 and 5) you have exactly the 1:1 image. After this adjustment it is no longer necessary to watch

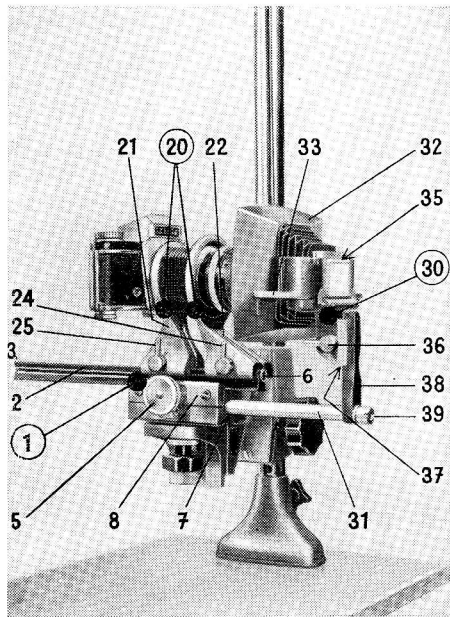

Fig. 7

the reflex image as long as your exposures are being made on the 1:1 ratio. It is advisable to stop down the diaphragm to f 8.

To avoid penetration of outside light, a transparency copying screen (32) has to be fixed at the projections (34) on the picture gate. To avoid outside light especially from the picture gate, it is profitable to work with the transparency copying equipment in a slightly darkened room.

As already mentioned, the single negatives, or negative strips, are inserted into the opened picture gate (35). Film trays (33) on both sides hold the ends of the strips. It is advisable to use the folded paper masks to push in the negative strips. The mask projects from the sides of the picture gate and can be moved sideways in both directions for critical adjustment of the picture outline in the 1:1 ratio and also when reproducing smaller singled-out parts of films. (See next section.) To make negative copies of 5 cm x 5 cm ready mounted

transparencies, the latter are inserted into the frame behind the projections (34).

Exposure takes place by means of the camera shutter.

As a rule, the scale of reproduction will be 1:1. It is also possible, however, to select smaller parts of a negative for the copy. This, of course, requires a somewhat longer camera extension, attainable, e. g. in the distance between camera holder and lens holder (21 and 22) in the bellows attachment. The negative is laterally adjustable in the picture gate (35), and the whole picture gate itself is arranged for vertical adjustment. The latter is achieved as before mentioned by loosening the lever (36) and moving the picture gate slightly up or down. The picture gate is fastened in position by turning down the lever.

Focusing is accomplished optically, based on the reflex image of the camera, and mechanically by actuating the rack-and-pinion mechanism of the focusing slide (1).

For the optical production of 35 mm transparencies from larger negatives, it is best to work with the apparatus in the vertical position, using the repro unit or the copying stand and some kind of lightbox. (See also note on page 24).

Nos. for ordering

Transparency copying equipment
(30) with ground-glass screen and
2 paper masks for single negatives
(for use with bellows attachment
only)

155.04

The Miniature Bellows Attachment

(Fig. 8)

Fig. 8

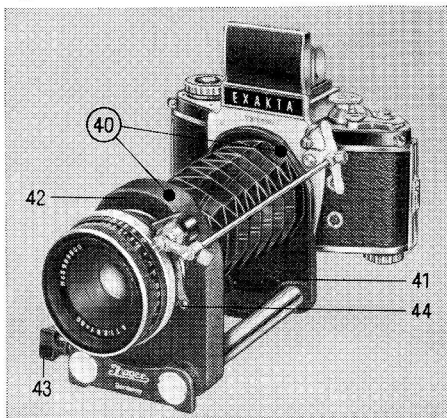

The miniature bellows attachment, (40) which is easily carried, is particularly intended for taking close-ups by hand, but, of course, it can also be employed on a tripod or on our copying stand. It is possible to fasten the camera to the camera holder (41) either in vertical or horizontal position. In case of horizontal positioning make sure that the red dot at the camera is exactly opposite the single red dot, and in case of vertical positioning it must be opposite the double red dots at the camera holder (41). Seen in viewing direction, swing the camera to the right until the locking lever at the camera bayonet clicks in. To secure the lens on the lens holder (42): Make sure that the red dots are opposite each other, give the lens a short turn to the right until the locking lever (44) at the lens holder clicks in.

Loosen the locking knob (43) at the lens holder (42) and set the desired extension increase, between 35 mm and 125 mm: push the lens holder (42) forward and secure it by means of locking knob (43). The graduation lines on the

right guide shaft are spaced 10 mm. The extension increase is read in front of the guide stud at the lens holder. During transportation, or when storing away, do make sure, for the sake of preserving the bellows, that camera holder and lens holder (41 and 42) are pushed together and that the lens holder is fixed!

When photographing by hand, the entire apparatus is easily pointed at the subject. When employing a tripod, we recommend the use of a sturdy ball and socket joint. Camera and lens holder have English tripod sockets ($1/4''$). When using tripod sockets with $3/8''$ an adapter must be employed. Either the tripod socket at the camera or at the lens holder may be used, depending on the centre of gravity of the apparatus. The tripod socket at the lens holder (42) is recommended for heavy lenses featuring long focal lengths. When employing the miniature bellows attachment with copying stand the tripod socket of the camera must be used (see page 23).

In order to employ the fully automatic pressure

or spring diaphragms of modern lenses, the autocouple extension release (with long coupling rod) is inserted between lens and camera (Fig. 8).

When photographing by hand, fine focusing is done by moving the entire apparatus to and fro, the desired scale of reproduction having been preset. The same focusing method is possible with the copying stand by means of its rack-and-pinion knob. If a tripod is used only, focusing can be accomplished by moving the lens holder (42) to and fro; in such a case, however, the scale of reproduction will change with the varying object distance.

With a standard 50 mm lens any measuring scale from 0.7 (extension 35 mm) to 2.5 (extension 125 mm) can be obtained, and subjects measuring from 34 mm x 51 mm down to 10 mm x 14 mm are fully shown on the negative. The special lens Jena T f 2.8/50 mm with sunk mount will assist you with the miniature bellows attachment (40) to reproduce larger subjects in full size and permit focusing to infinity.

With this special lens Jena T f 2.8/50 mm with sunk mount, the indicated extension increase must be reduced by 35 mm, so that extensions from 0 to 90 mm can be reached.

The miniature bellows attachment (40) is not practicable for wide angle lenses of shorter

than 35 mm focal length; however, any long-focus lens can be used, if its weight permits.

Nos. for ordering

Miniature bellows attachment (40)	176
Special lens Jena T f 2.8/50 mm with sunk mount	128

Copying Stand and Repro Unit

(Figs. 9 . . . 16)

These units are the basis of the "Vielzweck" outfit. Fundamentally they are intended as equipment to assist in reproduction work; however, they are equally useful as practical aids in many combinations as table stands, both for horizontal or vertical work.

The copying stand (500) will receive the camera directly, extension increase being obtained by inserting bayonet adapter rings and tubes or the miniature bellows attachment (40). The repro unit is used in connection with the bellows attachment (see page 8). Packing

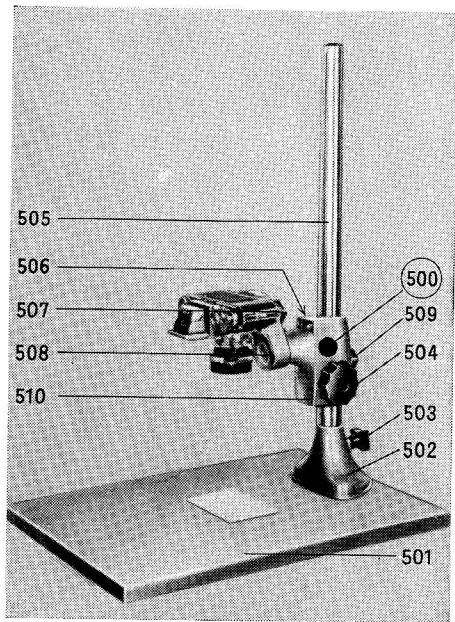
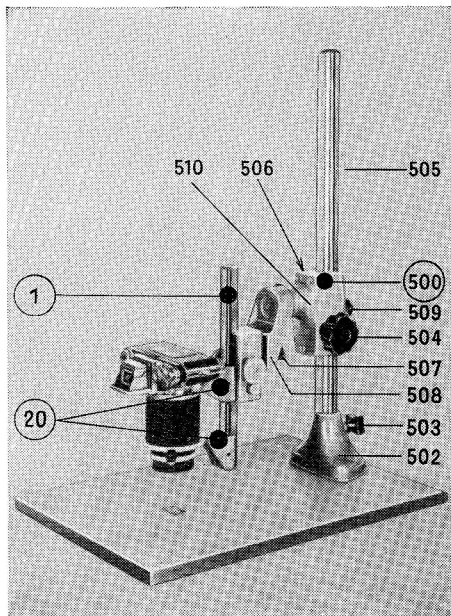

Fig. 9



facilities require repro stand and repro unit to be shipped separately. They are reassembled in the following manner; fasten column (502) to the wooden baseboard (501) by screwing the bolts with mounted washers through the baseboard from below into the column base (the washers must be placed between the bolt head and the baseboard). Thereafter insert the metal column (505) into the column base (502) and secure it by means of locking the screw (503). Loosening this screw will permit rotating the column. In this way it will be possible to turn the entire photographic apparatus 180° backwards, if objects at a large distance must be photographed (for instance from the edge of the table down to the floor). If necessary the baseboard (501) must be weighted.

The large hand-wheel (504) serves to move the column head (510) rapidly and effortlessly to any required height, where it is fixed by

Fig. 10

means of locking screw (509). When loosening the locking screw (506) located on the other side of the column head, then its front part (508) can be turned into the desired position where it will stay after the locking screw has been retightened.

The copying stand (500) will accept the camera with bayonet adapter rings and tubes or the miniature bellows attachment by means of the rotatable front part (508) of the column head. For repro unit, the bellows attachment together with camera and lens is fixed on the front part (508) of the column head. For this purpose, the attachment is equipped with two fixing screws (507 and 512) (one with $\frac{3}{8}$ " thread, the other with $\frac{1}{4}$ ""). The front part of the column head is turned upwards or downwards (see Figs. 9 and 10), the oblong hole pointing in a vertical direction. Camera or bellows attachment are screwed on the black protection strips by means of fixing screw (507) which has been pushed through the oblong hole. The locking nut of the fixing screw (507) must be drawn

tight against the black knob, and its bore must point towards the screwhead. Finally, the locking nut is screwed tight by turning it in the direction of the camera. For the above-described set-up, the small angular piece (511) see Figs. 11 and 12 - must be removed.

The desired scale of reproduction is obtained by the length of the extension increase (bayonet adapter rings and tubes, or bellows attachment, detailed information of which will be found on pages 8 and 18). Fine focusing is done by moving the column head (510) up or down and by control of the reflex image in the camera. It goes without saying that focusing with the repro unit can also be done with the rack-and-pinion drive of the focusing slide (1) after the column head (510) has been given the necessary distance from the baseboard (501). The baseboard (501) is suited for subjects measuring up to 21 cm x 29.7 cm.

When photographing transparent objects an illuminating box placed on the baseboard

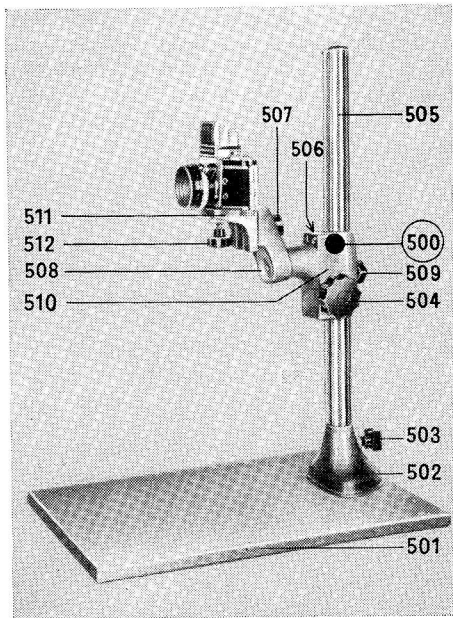

(501) will do. Such a box will render it possible to make either transmitted-light photographs from below, or incident-light photographs. The illuminating box will also serve for making miniature transparencies (35 mm) from larger negatives: For this purpose place the negative upon opal glass, which is illuminated from below, and proceed in the usual manner.

If copying stand or repro unit shall serve for working in horizontal direction (i. e. for pictures at a far distance, for reproductions of larger subjects fastened to a wall or for dose-ups), the angular piece (511) is turned in such a way that its black protection strips will lie horizontally upwards. The angular piece (511) is fixed with the second locking screw (512). The camera or bellows attachment are put on the black protection strips of the angular piece, locking screw (512) is passed through the oblong aperture at the angular piece and then camera or bellows attachment are screwed on in the

Fig. 11

already described manner. The camera can be set to any required position by simply turning column (505) and front part of the column head (508) (Figs 11 and 12). When taking horizontal pictures, with the aid of the Penta Prism, the camera being directly fixed on the angular piece (511), set the column head (510) high enough so that column (505) does not stand in the way when looking into the view-finder.

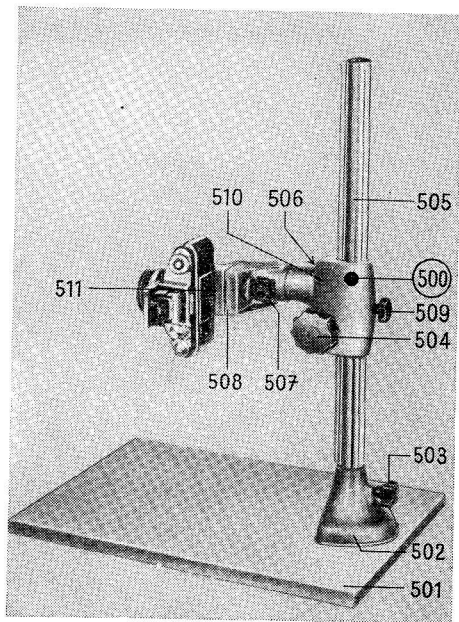
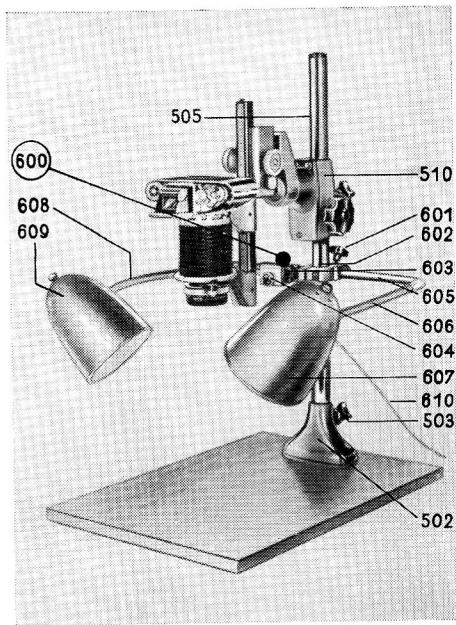

Fig. 12



Lighting Equipment, an accessory to Copying Stand and Repro Attachment (Fig. 13)

For the uniform lighting of reproduction objects or other close-ups the lighting equipment (600) can be applied by fixing it on repro unit or copying stand (Fig. 13).

Lighting equipment (600) is slipped on to the metal column (505) from its bottom end. Fixing screw (503) is loosened and column (505) is taken out of its foot (502), the lower end of the column is passed through clamping ring (602) and the column is replaced into its foot and fixing screw (503) is pulled tight.

The working position is adjusted to the subject to be reproduced. For enlargements of small objects, fasten the lighting equipment to the lower part of column (505) by means of clamp-

Fig. 13

ing screw (603). For scaled down reproductions of large objects, place the lighting equipment in the middle or at the upper end of column (505) and fasten by tightening screw (603). The position of the column head (510), however, must always be taken into account.

Small objects can have the reflectors (607 and 609) very near them; large objects, however, require the spacing large enough to permit uniform illumination. Both reflectors must be at equal distance from the centre of the object to be reproduced. When adjusting the position of the reflectors just loosen the holding device (605) by loosening clamping screw (601) and swing the reflectors (607 and 609) upwards and downwards.

Retighten the clamping screw (601) and bring the light source into position with the aid of the flexible arms (606 and 608). We recommend illumination at an angle of 45° in order to prevent flare. Cable (610) and switch (604) will connect to the mains.

Photomicrography with Repro Unit

(Figs. 14 and 15)

With the aid of a microscope attachment our cameras can be placed upon any commercially known microscope. Quite a few photographers do not like bringing the camera into direct touch with the microscope. The IHAGEE "Vielzweck" offers the possibility to join camera and microscope without rigid fastening of camera and microscope. In such a case repro unit is used as shown in Figs. 14 and 15. Lens holder (22), into which no lens has been set receives the light baffle (513). It is taken for granted that the microscope is equipped with a light-terminal sleeve (514) otherwise it must be procured from the manufacturers. Said terminal sleeve is slipped on the ocular fitting of the microscope. Both tubes must fit into each other in a way leaving no possible opening for penetrating light. The vertical arrangement will be found most suitable. The bellows attachment, which influences the scale of reproduction on the film will help to obtain the required

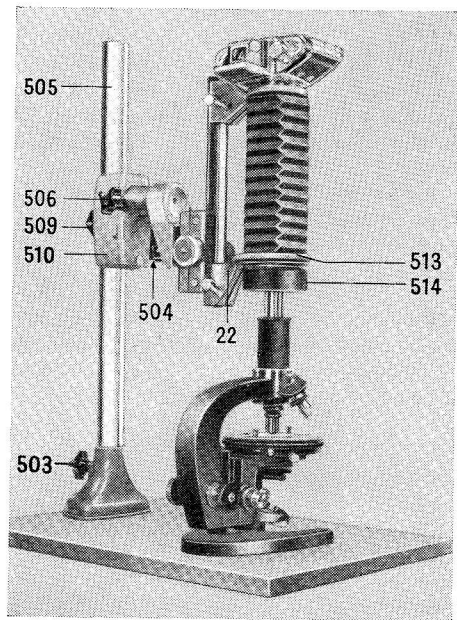

extension increase. More detailed information will be learnt after reading the special publications on photomicrography.

Column head (510) attached to column (505) can be set to the height of the microscope. The photographic equipment is centered over the microscope so that the camera, in this case without its lens, is exactly above the optical axis of the microscope, meaning that the image produced by the lens and ocular of the microscope is projected into the camera. For swinging column head (510) with camera attached just slacken clamping screw (503) and retighten after centering. Turn hand-wheel (504) and move the column head (510) downwards until the light protection devices (513 and 514) fit into each other, but do not contact. When interrupting your photographic work on the microscope, just move the column head a little upwards, loosen the fixing screw (503), and swing the whole apparatus to one side. When resuming

Fig. 14

the photographic work, just swing the apparatus back into its old position and continue the work.

With the aid of the Jena-Micro-Stands L and N you will find it possible to make extreme close-ups (lower magnification than micro-exposures). You choose a suitable lens, for example the special lenses Jena M and work without the ocular of the microscope. Remove the black tube of the microscope and replace it with the special microscope protective ring II (515) - Fig. 15 - which is set into the quick-change mount on the tube carrier of the Jena-Micro-Stands L and N. At the top of this special microscope protective ring II is the thread for receiving the ocular mount of the microscope. This mount must be screwed out of the black microscope tube and screwed into the mount of microscope protective ring II (515). As a result the space between lens and film plane has become narrower, in correspondence to the lower magnification, but, the method of working remains the same as described before.

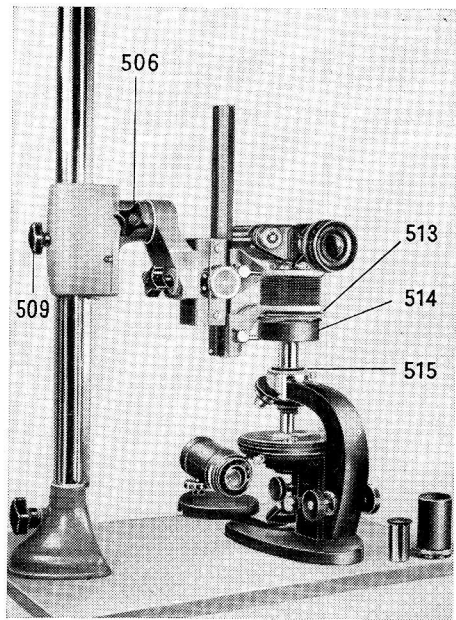

Fig. 15

Photomicrography with Repro Unit and Microscope Attachment (Fig. 16)

In photomicrography lenses yielding up to 10 fold enlargements sometimes reveal optical under-corrections, which can be decreased by simply lifting the ocular for focusing the reflex image in the camera. The equipment required consists of the repro unit and the microscope attachment (516) - Fig. 16 -.

The microscope is placed on the baseboard of the repro unit. Remove the ocular of the microscope, separate the lower part of the microscope attachment from its upper part by loosening the milled screw and fix the lower part on the ocular mount; replace the ocular and fasten the lower part by turning the notched to the left, during which performance the

knurled edge is held tight. Now, rejoin upper and lower part of the microscope attachment, but do not tighten the milled screw. The microscope is placed underneath the bellows attachment with camera on top so that the axis of microscope and microscope attachment are in line. Turning the pinion heads (4 and 5) of the focusing slide (1), or turning hand-wheel (504) will lower the whole apparatus until the bayonet ring located at the top of the microscope attachment engages with the bayonet mount of the lens holder (22). The red dots on bayonet ring and lens holder must be precisely on top of the other. The bayonet ring having slipped into the mount, the upper part of the microscope attachment must be turned until it snaps in. Thereafter you tighten the milled screw located on the quick-change mount of the microscope attachment and loosen its clamp ring, which, when working without the repro unit, normally holds the microscope adapter to the microscope. On turning the pinion head at the focusing slide or the hand-wheel at the column, the whole apparatus, microscope attachment

included, will move and you will be able to lift the ocular separately without the microscope lens.

Critical focusing is done as usual with the micrometer screw of the microscope.

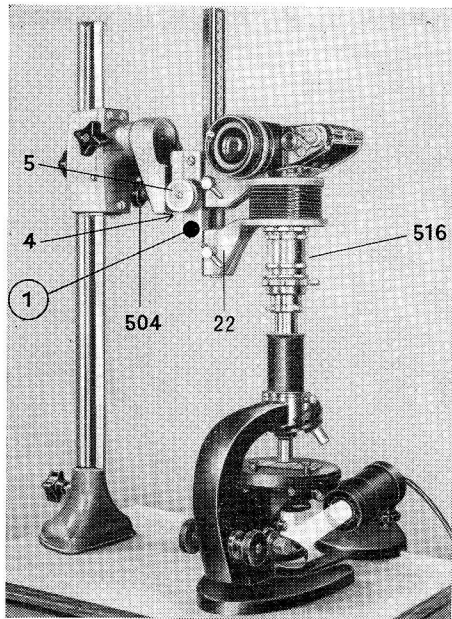

Fig. 16

**Nos. for ordering: Copying Stand, Repro Unit
and Accessories**

Copying stand (500)	155.16
Repro unit with bellows attachment (500 + 1 + 20)	155.20
Lighting equipment	213.12
Bellows attachment (1 + 20)	155.10

Miniature bellows attachment (40)	176
Special lens Jena T f 2.8/50 mm with sunk mount	128
Transparency copying equipment (30)	155.04
Light baffle tube (513)	156
Microscope protective ring II (515)	157
Microscope attachment (516)	153

Tripod plate with swing angle top

(Fig. 17)

An extra simple supplementary part, the tripod plate (70), equipped with Continental and English thread, has been designed for special work with the swing angle top (10). It can be screwed to any tripod. On the tripod plate (70) is a short slide rail (71) to accept the swing angle top (10), on which particulars have been given on page 3. The tripod plate will be found most convenient, where the camera is being used with long-focus or very heavy lenses (without a tripod socket of their own) perhaps, too, with an extra extension increase by means of bayonet adapter rings and tubes - see Fig. 17. In order to balance out the weight in such cases and to ensure tripod steadiness and

Fig. 17

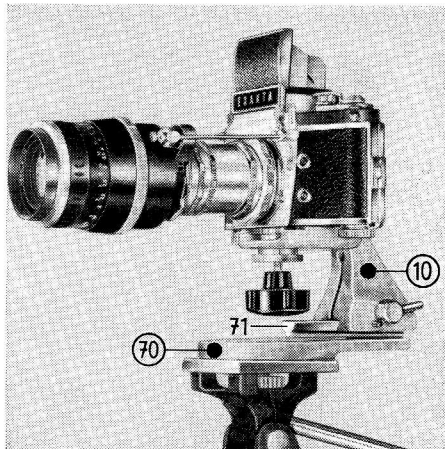

vibrationless working of the camera, the swing angle top (10) with the camera on the slide rail (71) has to be pushed away from the vertical axis of the tripod until the whole apparatus is equally balanced. Also, the movements of the swing angle top (10) on the slide rail (71) of the tripod plate prove very practical in close-up work. Tripod with camera can be set up firmly in front of the subject, nevertheless there is still sufficient play for focusing, due to

the fact that the swing angle top (10) can be moved to and fro on the slide rail.

Nos. for ordering

Tripod plate (70)	155.13
Swing angle top (10)	155.03

When ordering the swing angle top, we request you to state whether your camera has an English or Continental tripod socket.

The RB 1 Ring-Flash Unit

This can be used for practically every kind of close-up photography and provides one of the most convenient methods of taking close-up pictures by flash. With living subjects in particular (such as insects and small animals), the brief flash duration of the shutter-synchronized electronic flash tube ensures the highest possible definition. The constantly uniform frontal illumination provides a high light output and is virtually shadowless. The exposure data can be calculated to ensure that all objects which appear sharp on the reflex focusing screen will be correctly exposed (see table).

The Ihagee RB 1 Ring-Flash Unit is fitted with its own triggering equipment and can be connected to all electronic flash units up to 250 joules power output, with operating voltages up to about 500 V. The cable with which it is supplied is, therefore, not fitted with a plug connector, and a suitable connector must be obtained (the positive pole is indicated in colour on the cable). The RB 1 Ring-Flash Unit can be used

with the EXAKTA Varex and both EXA models, and also with miniature cameras produced by other manufacturers so long as these are used with suitable close-up accessories (such as bayonet rings and extension tubes or bellows attachments) for increasing the extension of the lens. (At large image scales, however, the EXA Ia and its preceding models will suffer from a certain amount of vignetting or cut-off along the long sides of the image field). The RB 1 Ring-Flash Unit can be screwed directly on to lenses with an M 49 x 0.75 mm front filter thread, and can be mounted on other lenses with the aid of adapter rings.

The Ihagee RB 1 Ring-Flash Unit is provided with a discharge tube coiled into a ring of comparatively small diameter and is, therefore, suitable for photographing the interiors of small cavities and hollow bodies which are accessible from the outside, such as bottles, jugs, tubes, cylinders and especially human and animal body cavities (see "Ihagee Kolpofot" overleaf). A 15 Watt 6 volt pilot light is used for focusing,

which can be adjusted in all three planes; a transformer providing an output voltage of 6 V is also necessary for using the pilot light. On account of the narrow diameter of the circular flash tube, it is only possible to use the ring flash unit with lenses having focal lengths of between 100 and 135 mm, working at image scales of approximately 0.5 upwards; at smaller image scales (greater lens-subject distance) the area covered by the lens will not be fully illuminated by the flash. The light-baffle tube of the ring-flash unit is provided with an M 24 x 0,5 mm screw-in thread for filters, photo-

micrography lenses, etc; adapter rings must be used for accessories with other threads. Details of the operating range of the Ihagee RB 1 Ring-Flash Unit and recommendations for its use will be found in the following table (the maximum image scale is that which can be obtained with the Ihagee Bellows Attachment at its full extension of 220 mm). The table is for black-and-white film, with standard fine grain development, and is based on the use of an electronic flash unit having an operating voltage of approx. 500 V and a discharge energy of 100 - 150 joules.

Image scale (B)	0.5	1.0	1.6	1.8	2.2
	Film speed rating and f/No.				
f 100 mm lens (Trioplan N f 2.8)	20 ASA/16 40 ASA/22	20 ASA/16-22 —	— —	— —	20 ASA/16-22 —
f 120 mm lens (Jena Bm f 2.8)	20 ASA/11 40 ASA/16	20 ASA/16 40 ASA/22	— —	20 ASA/16 40 ASA/22	— —
f 135 mm lens (Jena Sf 4 Primotar f 3.5)	20 ASA/8 40 ASA/11	20 ASA/11 40 ASA/16	20 ASA/11 40 ASA/16	— —	— —

When using colour film of the same nominal speed rating, increase the lens aperture by two f/stops (assuming normal processing in the case of negative colour film). It is always advisable to make test exposures using the lens and electronic flash unit which is to be employed.

Photo-micrographic lenses such as the Jena M can be used with very low-speed black-and-white films, provided that extensive test exposures are made. An adapter ring is available for attaching the RB 1 Ring-Flash Unit to the foremost extension tube or to the rear bayonet ring, which it may be necessary to fit on to the lens holder of the bellows attachment.

The Ihagee Kolpofot

The RB 1 Ring-Flash Unit when supplied with the bellows attachment and the Jena S 4/135 mm special lens, (which stops down to f 45) is known as the Kolpofot (Fig. 18). This combination has proved itself to be of excellent value in many fields, but especially in medical photography. Highly successful close-up pictures of the eyes, skin, teeth and ears, etc., can be taken with

ease and convenience. The Kolpofot is primarily employed, however, for photographing body cavities (vagina, mouth and pharynx, etc.). Despite its simple operation, it is possible to obtain intra vaginal pictures revealing even the finest structures with such clarity of detail that they can reliably be employed as a basis

Fig. 18

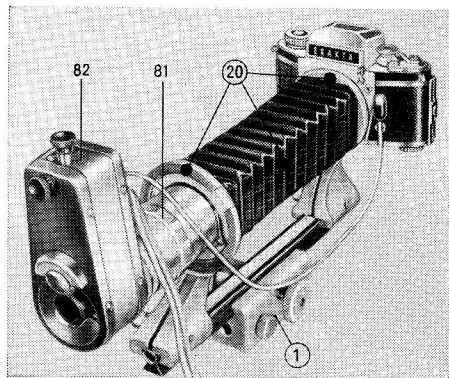

for diagnosis. In this way series of examinations, as in treatment of cervical cancer, can be prepared without difficulty. The long-focus lens (81) ensures that a favourable lens-subject distance of about 20 cm (8 inches) can be obtained, whilst in conjunction with the long bellows extension it provides a 1.6 times magnified image of the subject on the final negative. The Penta Prism of the EXAKTA Varex, which in this case is fitted with a clear screen with hair-lined cross, gives an image of 7 times magnification, so that in the most critical instances the finest structural details are easily recognizable.

Nos. for ordering

Ihagee Ring-Flash Unit RB 1 (82)
with pilot-light and cable only 196

Complete Ihagee Kolpofot including
bellows attachment (1 + 20),
Jena S 4/135 mm lens (81)
with pre-set diaphragm and aperture

closing to f 45,
RB 1 Ring-Flash Unit (82)
with pilot-light and cable 155.11

As above, but with Jena S 4/135 mm
lens having fully automatic dia-
phragm, and aperture closing to f 45 155.11 VSB

Jena S 4/135 mm lens (81)
with pre-set diaphragm and
aperture closing to f 45 437 A

Jena S 4/135 mm lens
with fully automatic diaphragm
and aperture closing to f 45 637 A

A twin cable-release is required for the fully automatic diaphragm of this lens.

It is necessary, when working with the complete Ihagee Kolpofot, to use a sturdy tripod with pan and tilt head.

Some hints concerning Macrophotography and Photomicrography

Focusing and control of depth of field are, also in macrophotography and photomicrography performed on the reflex image of our single-lens reflex cameras.

In macrophotography, as the distance between the subject and the lens becomes shorter, the image will increase in size. The image distance (distance between lens and film plane) increases when the subject distance decreases. Attention must be paid to the exposure factor, when working with extension tubes or bellows attachment. More detailed information concerning scales of reproduction, subject distance and image distance, etc. will be found in the instructions on "Macrophotography and Photomicrography" and "Tables for Close-ups" as well as in the special literature mentioned at the end of this booklet.

To facilitate determining the exact exposure time in photomicrography, stationary macro-

photography, and for optical copying of slides we recommend the IHAGEE Macro-Micro Photometer. A selenium top layer element is moved into the path of the light beam, thus allowing accurate measurement of the effective image-producing light inside the camera, evaluating also any eventual extension increase factor. A conventional micro-ammeter or galvanometer with light measurement scales is required.

As a useful accessory and focusing aid in macrophotography and photomicrography we recommend the Lens Magnifier to be inserted into the EXAKTA Varex instead of the Finder Hood or the Penta Prism. The lens magnifier makes it possible to focus and examine the reflected image with one of the highly corrected special lenses. Should there be no lens available for this purpose, then we recommend the top lens, designed especially for the Lens Magnifier.

The Fresnel Lens with split-image rangefinder (inserted upon request into the EXA II b, and available separately for the other two camera models) makes it possible to get the image

into sharp focus, also under unfavourable light conditions, when taking close-ups.

With a long camera extension and perhaps with a small lens opening, a darkening of the reflex image becomes unavoidable, so that it will seem desirable to focus through a clear spot in the ground glass straight on the bright aerial image. Close-ups from a 1:1 ratio upwards and photomicrographs can be made in this way with one of the special focusing magnifiers in the viewing systems of EXAKTA Varex and EXA 1a. The magnifiers have a hairline cross in the clear spot. They are available, also of completely clear glass with hairline cross. Upon request we can furnish individual types of magnifiers, with etched lines, squares, millimetre or centimetre division, etc..

Finally a few remarks have to be made regarding optical conditions in magnified photography with camera lenses. These lenses are highly corrected for ordinary exposures based on long subject distance and short image distance. But, whenever the negative picture al-

ready appears enlarged - and this is the case with magnified exposures - the image distance is greater than the subject distance. Therefore, in order to maintain the full working capacity of the lens, it is advisable, for magnifier exposures (especially those with more than 1,5 fold enlargement), to reverse the lens, turning the rear element in the direction of the subject.

This is possible with the aid of special "lens reversal rings". On one side, these rings have the thread for the tubes or for the rear bayonet ring, and on the other side is the thread to accept the front section of the lens. To fasten the "lens reversal ring" to the lens carrier of the bellows attachment, the rear ring of the pair of bayonet rings must first be screwed into the mount of the lens carrier. If the lens is mounted reversed on the bellows attachment, its scales become invalid. Scale of reproduction, exposure factor, image distance are best evaluated with the aid of a focusing magnifier featuring a millimetre division. Any type of millimetre rule is held in the focal plane, and

the size to which the subject has been enlarged can be read on the magnifier scale of the camera viewfinder.

Lens reversal rings are available for lenses with the following filter threads:

M 35.5 x 0.5	Nos. for ordering: 159/37
M 40.5 x 0.5	Nos. for ordering: 159/42
M 49 x 0.75	Nos. for ordering: 159/51

For over 5 times magnification, it is not advisable to use the camera lens, even in its reversed position. Instead, the photomicrographic lenses specially constructed for extreme close-ups, e. g. the "Jena M" should be used. For this purpose we supply adapter rings with screw

threads for these lenses. The adapter ring is screwed into the foremost tube. When using the bellows attachment, first insert the rear bayonet ring into the lens carrier; the adapter ring is then screwed into the bayonet ring.

Adapter ring for photomicrographic lenses, with international W 0.8" x $1/96$ thread or microscope lenses Nos. for ordering: 193/1

Adapter ring for photomicrographic lenses, e. g. the "Jena M", with a thread of M 26.5 x 0.5 Nos. for ordering: 193/2

EXA-Models and the Ihagee "Vielzweck"

The Ihagee "Vielzweck" is an essential part of the fully developed EXAKTA-system, and is therefore, mainly used with this high performance camera. But, in addition, the equipment may also be used with the EXA II b, the only reservation being that this model does not feature an interchangeable viewing system. The EXA I a, however, in conjunction with the Vielzweck is limited, in so far as when using the bellows attachment, the negative will suffer cut-off on its longitudinal sides (vignetting). This is unimportant when using the normal

lens with an extension of between 20 mm and 50 mm approximately, as a sufficiently large image will remain. A larger extension should be avoided. The EXA I a should not be used in conjunction with the transparency copying equipment or the Kolpofot.

The contents of this booklet require, to a certain extent, some knowledge regarding the applicability of our cameras and their accessories, as well as general skill in the photographic field. We call your attention to some leaflets, instruction booklets, and special literature. Please let us know your wishes and we shall be pleased to send you the booklets free of charge.

Special literature:

"EXAKTA 35 mm Photography" by Werner Wurst
(Published by VEB Fachbuchverlag, Leipzig)

"Photo-Excursions with the EXA" by Werner Wurst
(Published by VEB Fachbuchverlag, Leipzig)

These books are available only at special book stores.

IHAGEE KAMERAWERK AG · 8016 DRESDEN

Form 727 a/6/6607

Made in Germany

III/21/6 It 519/66 3232

