

Macrophotography and
Photomicrography

with the

EXAKTA
Varex

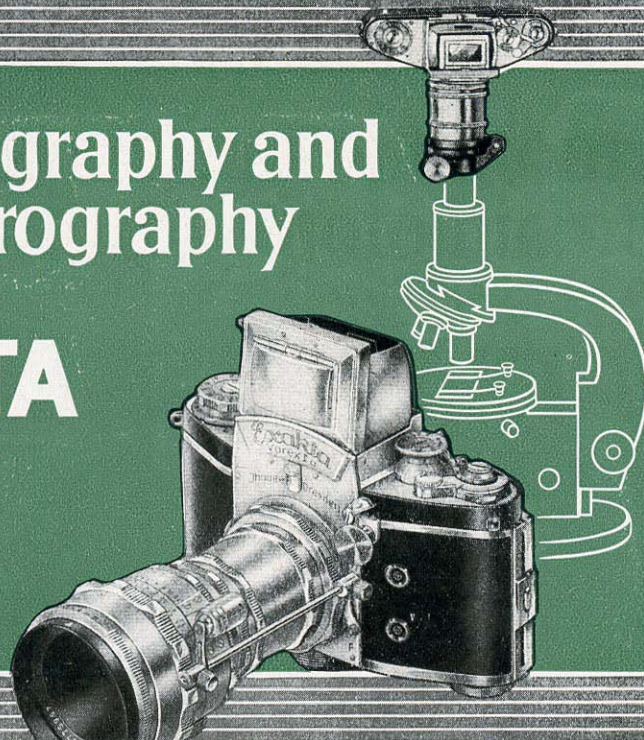

I N D E X		Page
	Macrophotography ..	3
	Two-in-One Adapter Ring	4
	Male and female Bayonet Adapter Rings and Extension Tubes	5
	Possible Extensions ..	6
	Locking Ring of the male Bayonet Ring	7
	Ihagee Autocouple Extension Release ..	8
	Advices for Close-ups ..	13
	Tables for Close-ups	
	Subject distance, Image distance, Picture size of the subject, Exposure factor, etc. ..	10 – 16
	The Ihagee "Vielzweck"	
	Reference to this universal equipment for close-ups and micro work and other spheres of photography	14 – 15
	Photomicrography	17
	Microscope Attachment Type 1	18
	Microscope Attachment Type 2 ..	19
	Special focusing glasses, Special Magnifiers	22
	The Lens Magnifier	24
	Magnifications, Table ..	27

The Extensions and the Micro-Adapters of the EXAKTA Varex can be used with all models, Kine-Exakta and with the EXA 24×36 mm (1½×1). There may be slight deviations between the camera models and the illustrations in this booklet.

Close-ups

Because the EXAKTA Varex is a single-lens reflex camera close-ups can be taken with it simply and easily. In accordance with optical laws the image distance (= distance between lens and film plane) increases, when the subject distance (= distance between lens and subject) decreases. Consequently, when focusing on a subject at a short distance from the camera, the distance between lens and film plane must be larger than attained by the helical focusing mount of the lens. Then extensions (bayonet rings and extension tubes) must be used. They are fitted in appropriate combinations, between lens and camera body (Fig. 1). It is a characteristic of the single-lens reflex camera that there is no need for special optical attachments for focusing at

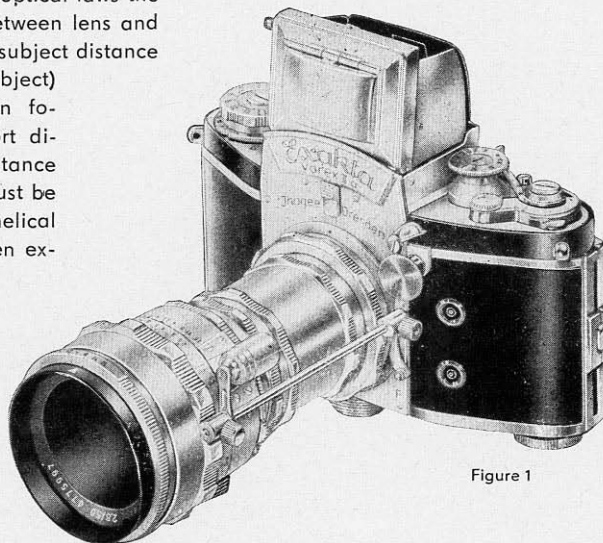

Figure 1

short distances; the ground-glass is used at all times for controlling of sharpness, depth of field, as well as for composing of the intended picture. The ground-glass screen image and the final picture are necessarily always identical, and parallax, which often can not be eliminated at short distances, never exists with the EXAKTA Vorex.

Two-in-One Adapter Ring (Figure 2, Cat.-No. 187)

For the minimum extension increase of 5 mm a Two-in-One Adapter Ring is available. It is made as one piece. It fits into the camera after the lens is removed and is inserted into the front bayonet, so that the red dots on the lens mount and on the front part of the Two-in-One Ring come to stand opposite each other. By a short turn to the right the lens locks into the stop-lever, which catches with a click. To remove the lens from the Two-in-One Ring, press the little release button of the adapter ring and turn the lens to the left, until the red dots are opposite each other again; then the lens can be removed from the adapter bayonet in the same manner as removing the lens from the camera. — Inserting the Two-in-One Adapter Ring into the camera is achieved in the same manner as attaching the lens alone. When the red dots on the camera and on the back part of the Two-in-One Ring are opposite each other, turn the adapter to the left, until the little lever on the camera snaps into position.

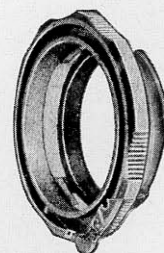

Figure 2

4

Male and female Bayonet Adapter Rings and Extension Tubes

(Figures 3 a–d, Cat.-No. 180)

The next extension increase is of 10 mm and is attained by the Pair of Bayonet Adapter Rings screwed together (Figure 3 a). Its handling is the same as that of the Two-in-One Adapter Ring. The Pair of Bayonet Adapter Rings differ from the Two-in-On Ring mainly in that, that they can be separated.

In order to increase extension additional Tubes must be screwed between the adapters. These Extension Tubes are supplied in 3 lengths: 5 mm (Figure 3 b), 15 mm (Figure 3 c), and 30 mm (Figure 3 d). They are sold in complete sets together with the Pair of Bayonet Adapter Rings. The Two-in-One Adapter Ring is, of course, supplied singly.



d

Figure 3

c

b

a

5

Possible Extensions

Two-in-One Ring, Pair of Bayonet Adapter Rings and Extension Tubes are as follows:

Extension of mm	Attainable with				
	Two-in-One Ring 5 mm	Pair of Bayonet Adapter Rings 10 mm	Tubes		
			5 mm	15 mm	30 mm
5	+				
10		+			
15		+	+		
20	+	+	+		
25		+		+	
30		+	+	+	
35	+	+	+	+	
40		+			+
45		+	+		+
50	+	+	+		+
55		+		+	+
60		+	+	+	+
65	+	+	+	+	+

This list of variable combinations may be extended to personal requirements by the addition of more tubes. – When using the Two-in-One Ring and a Pair of Bayonet Adapter Rings simultaneously, it is possible to attach the Two-in-One Ring to the back as well as to the front ring of the Pair of Bayonet Adapter Rings.

6

Locking Ring of the male Bayonet Ring (Figure 4)

The male Bayonet ring has a Locking ring serving the following purpose: When using the Pair of Bayonet Adapter Rings and Extension Tubes the lens is often turned on its axis so that the lens-scales are difficult to read. This can be avoided as follows: First turn the notch of the rear bayonet ring to the left (looking on face of camera), then you can turn the other extension increases with the lens into the position desired (e. g., when using the Autocouple Extension Release described on pages 8 and 9, the release buttons of camera and lens must lie exactly one behind the other).

By turning the notch for handling to the right the lens and the other extension increases firmly screwed together are fixed in this position. If the front extensions (front bayonet ring or tubes) shall be removed from the rear bayonet ring, turn the notch for handling also to the right, then the extension increases can be screwed out. When inserting and removing all extensions with rear bayonet ring, always seize the notch for handling.

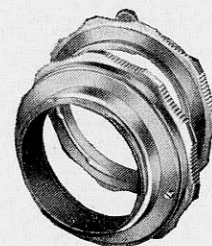

Figure 4

7

Ihagee Autocouple Extension Release

In normal practice employing lenses with A. P. D. presetting device first the diaphragm, and then the camera shutter are released. In normal practice the button of the Automatic Preset Diaphragm lenses which is situated immediately in front of the camera body release is first depressed, followed by the actual firing of the shutter by the camera body release. When employing Bayonet Adapter Rings and Extension Tubes, however, the Ihagee Autocouple Extension Release has been produced specifically in order that the automatic lens mechanism may still be used. It consists of the following single parts:

- a) the coupling rod
- b) the release part
- c) the pressure part and
- d) the push button.

According to the length of the additional extension release part b) and pressure part c) are adjustable and interchangeable on the coupling rod a).

In actual practice there are, basically, two possibilities as follows:

(1) For short extension up to 15 mm (Two-in-One adapter ring, Pair of Bayonet Rings with or without a 5 mm Extension Tube) the Autocouple Extension Release is assembled as shown in Figure 5.

In this instance, pressure part c) with push button d) are screwed into the release button of the lens, whilst the pointed contact of release part b) is inserted into the Release Button on the EXAKTA Vorex. The distance between the Release Button and pointed contact having been adjusted according to the length of the actual extension, by tightening the knurled locking screws. In this way the coupling between the two release buttons is restored, and by single pressure of the finger on release button d) both the lens diaphragm and the camera shutter are released simultaneously.

(2) For extension from 20 mm to 60 mm (pair of Bayonet Adapter Rings and Extension Tubes) parts b) and c) must be reversed. In this case, therefore, the pointed contact of part b) is inserted into the lens release and the pressure part c) is screwed to the camera release by means of release button d). Then

8

as previously stated the knurled screws are tightened and the camera is then ready for releasing again. Automatic single pressure coupling is thus achieved as described above (see Figure 6).

In order to guarantee perfect functioning, please, note the following when connecting the Autocouple Extension Release to the camera:

When the pointed contact of the release part has been inserted into the release button, the pressure part has to be close to the release button (always mount the Autocouple Extension Release to the camera with diaphragm wound up).

Besides, the coupling rod should always be parallel to the optical axis. This is easily achieved by turning the lens so that both release buttons lie in the same direction, also when using additional extensions.

For this purpose the rear bayonet ring (next to the camera) is fitted with a locking device (described on page 7).

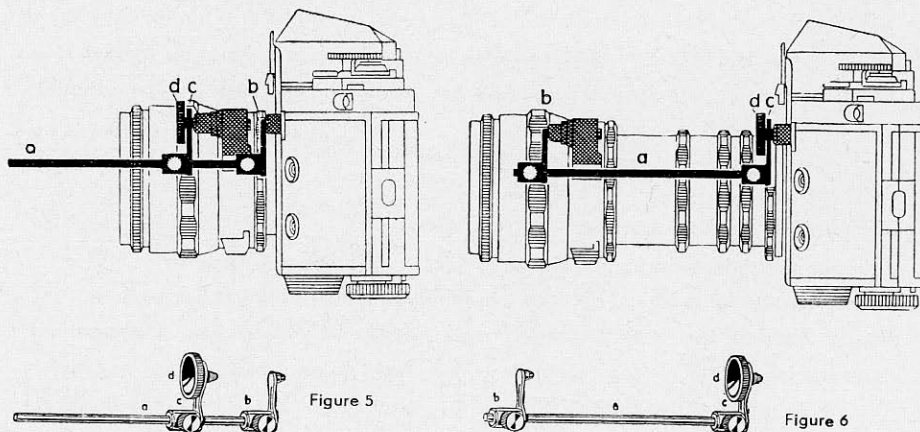

9

The following Tables

contain all data for close-ups with lenses of 50, 58, 100, and 135 mm focal length and facilitate the selection of the extension increases. The tables give calculated values which may differ a little from the real values because of the admissible tolerances of the focal distances of the lenses. However, these small differences can be neglected when applying the tables to any kind of regular work. The figures of the tables are for the lens set at infinity (∞). Intermediate values are found by focusing at shorter distances (means lower figures in metres). By adding tubes you will get greater enlargement on the negatives, according to the length of extension.

Extension Increase

i. e. the total length of the bayonet rings and tubes

of the same length as the focal distance = pictures 1 : 1 on the negative

of double length of the focal distance = double magnification on the negative

of triple length of the focal distance = three times magnification on the negative

of quadruple length of the focal distance = four times magnification on the negative

of quintuple length of the focal distance = five times magnification on the negative, etc.

10

The following is an explication of the tables:

Subject distance = distance from subject to lens
(about lens diaphragm plane) Figure 7

Image distance = distance from film plane to lens
(about lens diaphragm plane) Figure 7

Total distance = distance from subject to film plane
(= subject distance + image distance) Figure 7

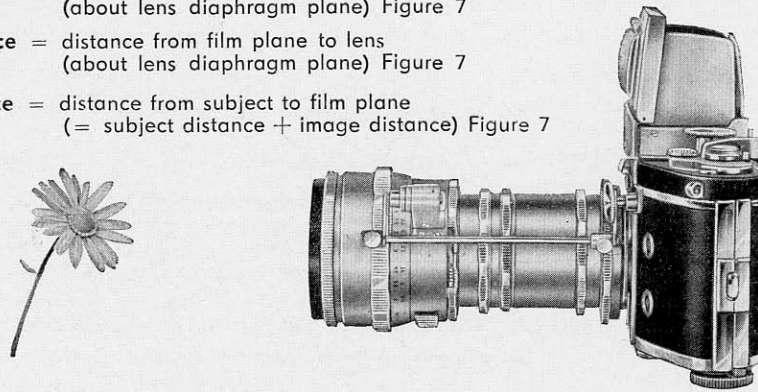
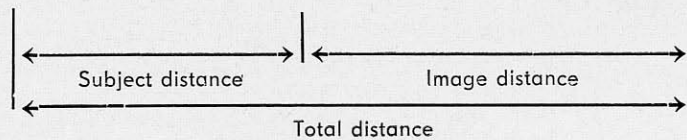

Figure 7



11

Scale of reproduction = ratio of subject to image

e. g. 1 : 1 = 1,0 means: subject and image are of same size.

1 : 2 = 0,5 means: the image is half as large only as the subject.

2 : 1 = 2,0 means: double size of image = two times-enlargement.

Picture size of the subject

means, how much of length and height of the subject is covered by the film. Here, partly, round figures in millimetres are quoted.

Exposure factor

When working with increased extension, the exposure time must be longer, for there will be a diminution of light with the increasing image distance. Therefore the exposure time for a certain diaphragm opening must be multiplied by an exposure factor corresponding to the extension increase. When focusing at short distance with the lens helical focusing mount alone there is a small exposure increase only that can be overlooked, but with longer extensions it has to be calculated according to the following formula:

$$\text{exposure increase} = \left(\frac{\text{image distance}}{\text{focal distance}} \right)^2$$

Example: Extension increase with the Pair of Bayonet Adapter Rings and all 3 tubes (= 60 mm). Length of the image distance = lens focal distance e. g. f = 50 mm + extension increase e. g. 60 mm = 110 mm.

The focal distance is 50 mm in length. 110 : 50 = 2,2.

2,2 · 2,2 = 4,84. Thus, in this case, the exposure factor is 4,8, in other words the normal exposure time must be multiplied practically by 5.

12

Increases of extension can also be used with other lenses not yet mentioned. For a certain scale of reproduction you will attain, when using a wide angle lens, a shorter subject distance, and with a long focus lens, a longer subject distance than with a normal lens. Both cases are possible in practice. Focusing is done on the ground glass screen as usual. Tables for close-ups with special lenses up to f = 35 mm focal distance are available and will be sent on request free of charge.

Close-ups with great magnifications of the subject require relatively long image distances and short subject distances. Our lenses are, however, corrected for the reverse ratio, that is long subject distance and short image distance. Therefore, we recommend for close-ups with magnifications of more than 2,5 times, to use the lens in reverse position i. e. with its back turned towards the subject and the lens front facing the film. We supply reversal rings with which to screw the lens on the front extension tube. When using the lens this way, there is no possibility of helical focusing, therefore, critical focusing is done by slight changes of the camera position.

For taking pictures with over 5 times magnifications we recommend the Microtars. As special lenses for macro-photos, they must, of course not be attached inversely.

13

Tables for close-ups with focal distance lenses of 50 mm and 58 mm

For lens focal distance of 50 mm							For lens focal distance of 58 mm					
xtension crease	bject stance	nage distance	otal distance	cale of roduction	icture size f the subject	xposure ctor	bject stance	nage distance	otal distance	cale of roduction	icture size f the subject	xposure ctor

Micro equipment, Fig. 8

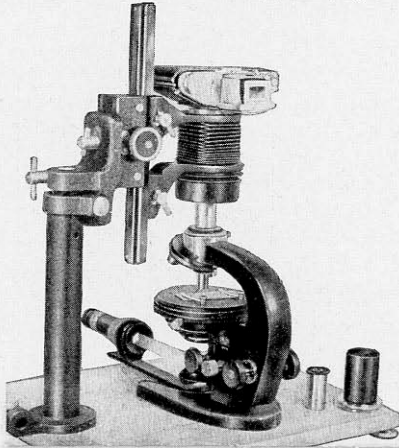

Important Note:

Close-up and micro exposures with the EXAKTA Varex are not only obtainable with the accessories described in this booklet. For achieving utmost economy in this field, as well as in other spheres of photography, the "Vielzweck"-Multi-Combination for the EXAKTA Varex has been designed. Please ask for information, also regarding this equipment, the versatility of which you will find most welcome. We shall be glad to send you a detailed brochure. Here just a short reference to the individual groups of the "Vielzweck": For close-

Tables for close-ups with focal distance lenses of 100 mm and 135 mm

For lens focal distance of 100 mm							For lens focal distance of 135 mm					
xtension crease	bject stance	nage distance	otal distance	cale of roduction	icture size f the subject	xposure ctor	bject stance	nage distance	otal distance	cale of roduction	icture size f the subject	xposure ctor

up and magnifier work there is the Bellows Attachment (Fig. 9). Reproductions are conveniently carried out with the help of the Copying Stand, which, by the way, also serves as a sturdy table tripod for other purposes. The Bellows Attachment and Copying Stand combined are used for photomicrography (Fig. 8). Duplicates of small transparencies, on an optical basis, are made with the Transparency Copying Attachment. For medical photography, especially for photographing cavities of the body, the "Kolpofot" has been especially constructed. It works in connection with an electronic flash unit.

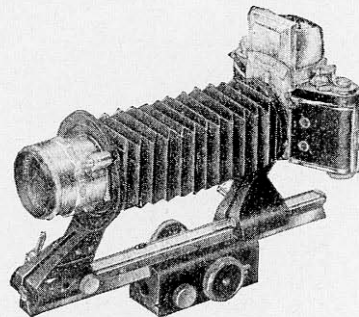

Bellows Attachment (Cat.-No. 155.13), Fig. 9

Tables for close-ups with focal distance lenses of 50 mm and 58 mm

Extension increase mm	For lens focal distance of 50 mm						For lens focal distance of 58 mm					
	Subject distance mm	Image distance mm	Total distance mm	Scale of reproduction	Picture size of the subject mm	Exposure factor	Subject distance mm	Image distance mm	Total distance mm	Scale of reproduction	Picture size of the subject mm	Exposure factor
0	∞	50	∞	different	variable	1,0	∞	58	∞	different	variable	1,0
5	550	55	605	0,1	240×360	1,2	731	63	794	0,09	267×400	1,2
10	300	60	360	0,2	120×180	1,4	394	68	462	0,17	141×212	1,4
15	217	65	282	0,3	80×120	1,7	282	73	355	0,26	92×138	1,6
20	175	70	245	0,4	60×90	2,0	226	78	304	0,35	69×103	1,8
25	150	75	225	0,5	48×72	2,3	192	83	275	0,43	56×84	2,1
30	133	80	213	0,6	40×60	2,6	170	88	258	0,52	46×69	2,3
35	121	85	206	0,7	34×51	2,9	154	93	247	0,60	40×60	2,6
40	113	90	203	0,8	30×45	3,2	142	98	240	0,69	35×52	2,9
45	106	95	201	0,9	27×40	3,6	133	103	236	0,78	31×46	3,2
50	100	100	200	1,0	24×36	4,0	125	108	233	0,86	28×42	3,5
55	95	105	200	1,1	22×33	4,4	119	113	232	0,95	25×40	3,8
60	92	110	202	1,2	20×30	4,8	114	118	232	1,03	23×35	4,1
70	86	120	206	1,4	17×26	5,8	106	128	234	1,21	20×30	4,9
80	81	130	211	1,6	15×23	6,8	100	138	238	1,38	17×26	5,7
90	78	140	218	1,8	13×20	7,8	95	148	243	1,55	15×23	6,5
100	75	150	225	2,0	12×18	9,0	92	158	250	1,72	14×21	7,4
110	73	160	233	2,2	11×16	10,2	89	168	257	1,90	13×19	8,4
120	71	170	241	2,4	10×15	11,6	86	178	264	2,07	12×17	9,4
130	69	180	249	2,6	9×14	13,0	84	188	272	2,24	11×16	10,5
140	68	190	258	2,8	9×13	14,4	82	198	280	2,41	10×15	11,7
150	67	200	267	3,0	8×12	16,0	80	208	288	2,60	9×14	12,9
160	66	210	276	3,2	8×11	17,6	79	218	297	2,76	9×13	13,8
170	65	220	285	3,4	8×11	19,4	78	228	306	2,92	8×12	15,5
180	64	230	294	3,6	7×10	21,2	77	238	315	3,09	8×12	16,8
190	63	240	303	3,8	6×9	23,0	76	248	324	3,26	7×11	18,3
200	63	250	313	4,0	6×9	25,0	75	258	333	3,44	7×10	19,8

Tables for close-ups with focal distance lenses of 100 mm and 135 mm

For lens focal distance of 100 mm							For lens focal distance of 135 mm					
Extension increase mm	Subject distance mm	Image distance mm	Total distance mm	Scale of reproduction	Picture size of the subject mm	Exposure factor	Subject distance mm	Image distance mm	Total distance mm	Scale of reproduction	Picture size of the subject mm	Exposure factor
0	∞	100	∞	different	variable	1,0	∞	135	∞	different	variable	1,0
5	2100	105	2205	0,05	480×720	1,1	3780	140	3920	0,04	600×900	1,1
10	1100	110	1210	0,10	240×360	1,2	1958	145	2103	0,07	343×514	1,2
15	767	115	882	0,15	160×240	1,3	1350	150	1500	0,11	218×327	1,2
20	600	120	720	0,20	120×180	1,4	1046	155	1201	0,15	160×240	1,3
25	500	125	625	0,25	96×144	1,6	864	160	1024	0,19	126×189	1,4
30	433	130	563	0,30	80×120	1,7	742	165	908	0,22	109×164	1,5
35	386	135	521	0,35	69×103	1,8	656	170	826	0,26	92×138	1,6
40	350	140	490	0,40	60×90	2,0	591	175	766	0,30	80×120	1,7
45	322	145	467	0,45	53×80	2,1	540	180	720	0,33	73×109	1,8
50	300	150	450	0,50	48×72	2,3	500	185	685	0,37	65×97	1,9
55	282	155	437	0,55	44×65	2,4	466	190	656	0,41	59×88	2,0
60	267	160	427	0,60	40×60	2,6	439	195	634	0,44	55×82	2,1
70	243	170	413	0,70	34×51	2,9	395	205	600	0,52	46×69	2,3
80	225	180	405	0,80	30×45	3,2	363	215	578	0,59	41×61	2,5
90	211	190	401	0,90	27×40	3,6	338	225	563	0,67	36×54	2,8
100	200	200	400	1,00	24×36	4,0	317	235	552	0,74	32×49	3,0
110	191	210	401	1,10	22×33	4,4	301	245	546	0,82	29×44	3,3
120	183	220	403	1,20	20×30	4,8	287	255	542	0,89	27×40	3,6
130	177	230	407	1,30	18×27	5,3	275	265	540	0,96	25×38	3,9
140	171	240	411	1,40	17×26	5,8	265	275	540	1,04	23×35	4,2
150	167	250	417	1,50	16×24	6,3	257	285	542	1,11	21×32	4,5
160	163	260	423	1,60	15×23	6,8	249	295	544	1,18	20×30	4,8
170	159	270	429	1,70	14×21	7,3	242	305	547	1,26	19×29	5,1
180	156	280	436	1,80	13×20	7,8	236	315	551	1,33	18×27	5,4
190	153	290	443	1,90	13×19	8,4	231	325	556	1,41	17×26	5,8
200	150	300	450	2,00	12×18	9,0	226	335	561	1,48	16×25	6,2

Reproductions of DIN-patterns with the EXAKTA Varex

Pattern	Extension increase in mm	Lens f = 50 mm		Lens f = 58 mm		
		image distance mm	Lens-to-subject distance mm	Extension increase in mm	Image distance mm	Lens-to-subject distance mm
DIN A 0 (84,1x118,9 cm)	1,5	51,5	1800	1,5	59,5	2090
DIN A 1 (59,4x 84,1 cm)	2,0	52,0	1290	2,5	60,5	1500
DIN A 2 (42,0x 59,4 cm)	3,0	53,0	930	3,0	61,0	1070
DIN A 3 (29,7x 42,0 cm)	4,0	54,0	670	4,5	62,5	775
DIN A 4 (21,0x 29,7 cm)	5,5	55,5	490	6,5	64,5	570
DIN A 5 (14,8x 21,0 cm)	8,0	58,0	360	9,5	67,5	415
DIN A 6 (10,5x 14,8 cm)	11,5	61,5	270	13,0	71,0	310
DIN A 7 (7,4x 10,5 cm)	16,0	66,0	205	18,5	76,5	235
DIN A 8 (5,2x 7,4 cm)	23,0	73,0	160	27,0	85,0	185
DIN A 9 (3,7x 5,2 cm)	32,5	82,5	125	37,5	95,5	145
DIN A 10 (2,6x 3,7 cm)	46,0	96,0	105	54,0	112,0	120

The small extension increases are obtained with the helical focusing of the lens. The lenses of the anterior models of the EXAKTA or of the Kine-Exakta require an additional extension increase by Adapter Rings and Extension Tubes already with the size DIN A 4, while the new long lenses in helical mount want Adapter Rings and Extension Tubes from DIN A 5 only. At any rate, when using additional mechanical extension increases, the exact image distance is focused with the lens in helical mount.

The measurement indicated in the table are calculated values. They are founded on the supposition that the short side of the DIN-pattern is always focused on 24 mm-image (short side of the negative size 24x36 mm). In practice the indications in the table can a little differ from the measurements really attained (focal length tolerances of the lenses).

16

Photomicrographs

The single-lens reflex camera EXAKTA Varex opens also – similarly to close-ups – the large field of Photomicrography, by simple and inexpensive accessories. The reflex screen image serves for focusing and observing the microscopic picture. You observe it until you press the shutter release button.

The two Microscope Attachments

(Figures 10 and 13)

connect the EXAKTA Varex to any microscope. The camera can be adapted with one of the two attachments to the ocular tube of the microscope which has the standard outside diameter of about 25 mm. Microphotographs are taken with the optical system of the microscope and not with the camera lens.

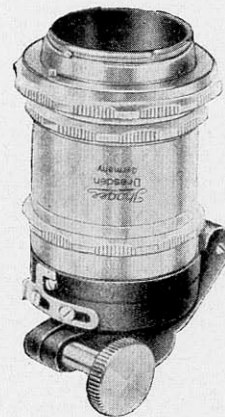
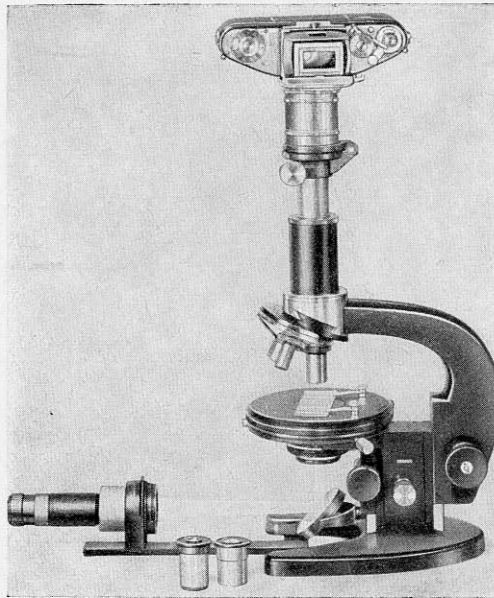

Figure 10

17



Microscope Attachment Type 1

(with hinged clamp, Figure 10,
Cat.-No. 188)

The camera is fixed to the top part of the attachment: The bayonet ring is put into the camera-bayonet in the same way as a lens. To attach the combination of camera and attachment to the microscope, remove first the ocular from the microscope tube. Camera and attachment tilted up are put on the tube — see Figure 11 —, the ocular is replaced and, by a slight turn of the clamping screw, the microscope-attachment is

Figure 11

fastened to the microscope tube. Then the camera is tilted up and the microscope-attachment bolted up (Figure 11). By means of the hinged clamp the camera can always be tilted to the side, when photographic work is being suspended (Figure 12) for exchanging oculars or when subject observation should continue.

Microscope Attachment Type 2

(in Quick-Change-Mount, Figure 13,
Cat.-No. 153)

Top and bottom parts of this attachment can be separated by loosening

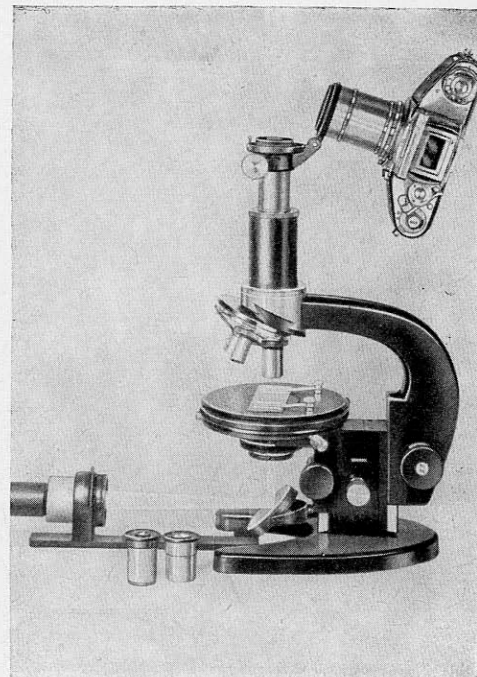

Figure 12



Figure 13

20

the quick-change-mount: The indented screw is slightly screwed out and the top part of the microscope attachment lifted out of the mount. The top part is attachable by its bayonet ring to the camera as usual. Then, after removing the ocular of the microscope, push the bottom part of the microscope-attachment over the ocular tube, replace the ocular and fasten the bottom part on the notch-ring by turning it to the left, whereby the grip-border must be held fast. The top part of the micro-attachment with the camera is put into the quick-change-mount: First place the cone under the two latches, then the opposite side slides into position. Tight the set screw, and make the top part in the mount safe to operate. Figure 14 shows the combination ready to work.

The top part cone of type 2 of our microscope-attachment is also adaptable to all microscopes with tubes of 25 mm diameter. On these microscopes the tube is removable and the EXAKTA Varex together with the top part of the micro-attachment is placed into the

switch mount of the tube support of the microscope. It is possible to take so-called "Lupen" Pictures – Macro photographs – with the microscope objective alone. The Microtars are especially qualified for this purpose, Figure 15. We regret that it is impossible to give here technical instructions for taking photomicrographs. This field is so large that it will be of no use picking out a few points only. We rather recommend to consult one of the many books about this subject. (Please refer to notes on page 27.).

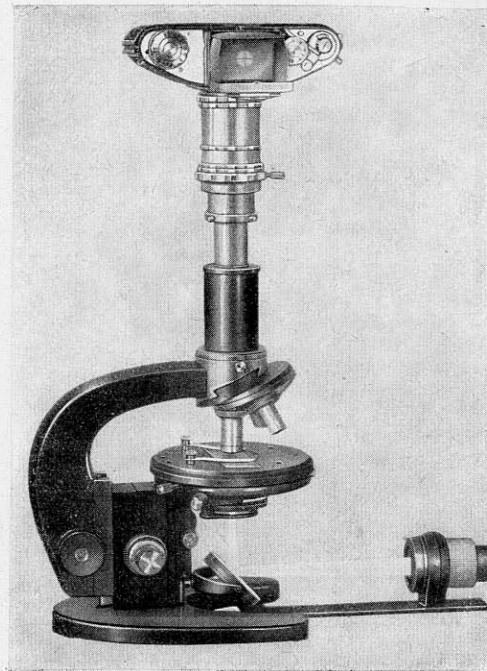
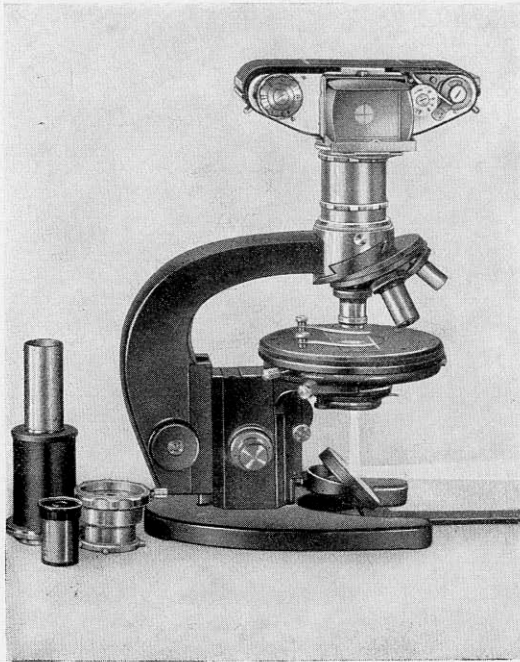

Figure 14

21



Special focusing glasses

(Figure 16)

The possibility of instantaneously interchanging the focusing glasses of the EXAKTA Varex is of great advantage for taking micro- and "Lupen" (macro) pictures. You can use, instead of the regular ground glass, the special glasses described below. Although it is desirable to compose the image on a ground glass, the sharpness must be determined through the clear centre spot by focusing into the air. In taking "Lupen" photos a fully clear glass proves to be

Figure 15

indispensable. The ground glass of the reflex finderhood is on the under part of the large magnifying glass, which may be removed from the framework by loosening the two holding screws and replaced by the desired type of glass. It is, however, recommended to purchase an additional complete reflex finderhood with the desired glass for the sake of greater convenience, particularly as the price is not high. With the Penta Prism, however, the ground glass can be changed and consequently special glasses alone are available for it.

The following special glasses are offered:

- a) Reflex Finderhood with ground glass and clear center spot of 3 or 10 mm diameter (both with hairline cross in the clear spot),
- b) Reflex Finderhood with focusing glass completely clear and cross hairlines,
- c) Ground glasses for Penta Prism with clear center spot of 3 or 10 mm diameter (both with hairline cross in the clear center spot),
- d) completely clear glasses with cross hairlines.

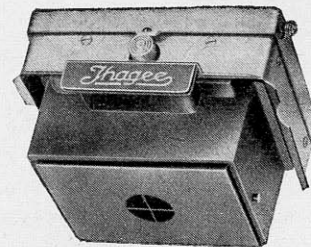
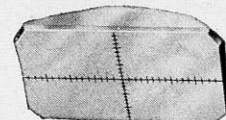
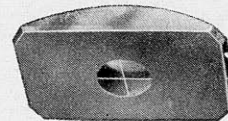

Figure 16,



The focusing systems with clear center spot or clear overall are also practical for endoscopic pictures in medical photography. The cross hairlines avoid, at all times, the unwanted continuation accommodation by the eye. In Photomicrography correct focusing is attained, when both cross hairlines and image appear to be simultaneously sharp. When moving the eye over the clear spot to and fro, cross hairlines and image must not shift each against the other, if correctly focused. The same should happen when taking "Lupen" pictures. Other special types of focusing glasses can be supplied according to specifications (e. g. with etched cross lines, cm or mm graduations, etc.).

Please write to our "Service Department"!

Lens Magnifier (Figures 17 and 18, Cat.-No. 308)

The supplementary magnifying lens in the Finderhood of the EXAKTA Varex does not always meet the great optical requirements of critical focusing in close-up and micro-work. Therefore the "Lens Magnifier" was designed for the specialised fields of Macro photography and Photomicrography. It can be inserted into the EXAKTA Varex instead of the Finderhood or Penta Prism, and makes possible to focus and examine the reflected image with one of the highly corrected EXAKTA Varex normal and Special lenses. The lens is, as figure 17 shows, set in the bayonet mounts of the Lens Magnifier. Focused at infinity, it shows a magnified and evenly sharp reflected image without distortion or aberration.

24

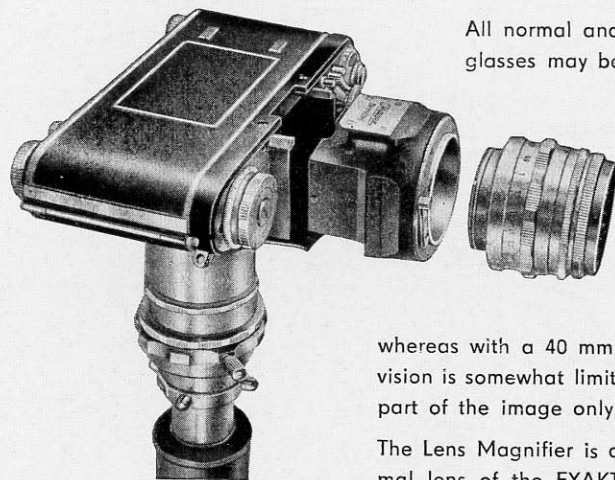

Figure 17

All normal and special ground or clear focusing glasses may be used in the Lens Magnifier (see preceding section). With a partially or completely clear screen, the image is easily and quickly discernable. The normal or long-focus lenses when used as critical magnifiers permit to examine the whole area of the reflected image,

whereas with a 40 mm picture taking lens the range of vision is somewhat limited so that you will see the centre part of the image only.

The Lens Magnifier is all the more practical as the normal lens of the EXAKTA Varex is not used for taking Photomicrographs, thus being free for serving as magnifier. For the reflex image magnifications possible with the different lenses see the following table. Additional

magnifications can be obtained, when holding a small pocket telescope as supplementary focusing help over the Lens Magnifier (e. g. the Tellup giving a 2,5 times magnification).

25

The total magnification results from multiplying the lens magnification with that of the pocket telescope. The modern lenses the mounts of which offer the comforts of the pre-set diaphragm and the automatic diaphragm pre-setting device and additionally operate as a natural light trap, too, have, however, when used as a magnifier, a distance somewhat too large between frontlens and eye, so that you can no more see the full ground-glass image. For the Lens Magnifier, therefore, an additional magnifying glass was made, effecting a magnification of about $4\frac{1}{2}$ times (thus total magnification with the magnifying ground glass about 5 times). So you can very well control and accurately focus the total ground-glass image owing to the good optical performance of the additional magnifier.

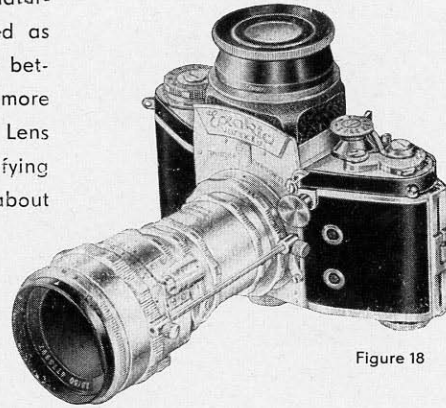

Figure 18

This magnifying glass is mounted in the same way as a lens of the EXAKTA Varex and inserted so, too, in the bayonet of the Lens Magnifier.

Magnification

Lens with 40 mm focal distance	7,0 times	with Tellup	17,5 times
Lens with 50 mm focal distance	5,4 times	with Tellup	13,5 times
Lens with 58 mm focal distance	4,9 times	with Tellup	12,3 times
Lens with 75 mm focal distance	3,8 times	with Tellup	9,5 times
Lens with 100 mm focal distance	2,8 times	with Tellup	7,0 times
Lens with 135 mm focal distance	2,1 times	with Tellup	5,3 times

Literature

If you are interested in the EXAKTA Varex and accessories, please do inform us of your specific requirements.

Details on the most important spheres of macro- and micro-photography will also be found in the book "EXAKTA Makro- und Mikro-Fotografie" by Dipl.-Opt. Georg Fiedler. The general basic instruction book bears the title "EXAKTA Kleinbild-Fotografie" and its author is Werner Wurst. Both books (only in German) are published by Wilhelm Knapp, Halle (Saale), and are available at book shops.



DRESDEN A 16